

P/N 52-0057 L-BRACKET SUPPLIED WITH THE AES 3 dB, 5 dB AND PHANTOM ANTENNAS

Insert the 4 ground radials into the brass mount adapter. Secure the radials by tightening the four set screws in the adapter.

For operation in the following bands, the length of the radials should be cut to:

144-174 MHz	22"
400-512 MHz	7"

Adjust the position of the connector bushing so the top surface of the contact pin sits 1/16" above the surface of the brass mount adapter. Secure the main threaded adapter by tightening the nut and lock washer from below the mounting bracket.

Attach Stainless steel mounting bracket to a mast using the supplied stainless steel hose clamps. For mounting to a wall or post use lag screws (not supplied).

AES supplies this antenna bracket assembly with N-Type connections which are preferred at our typical frequencies.

If the radials supplied are bent slightly, make sure the installation is done with the radial ends sloping downward. At frequencies above 450 MHz, a slight downward slope may provide better impedance.

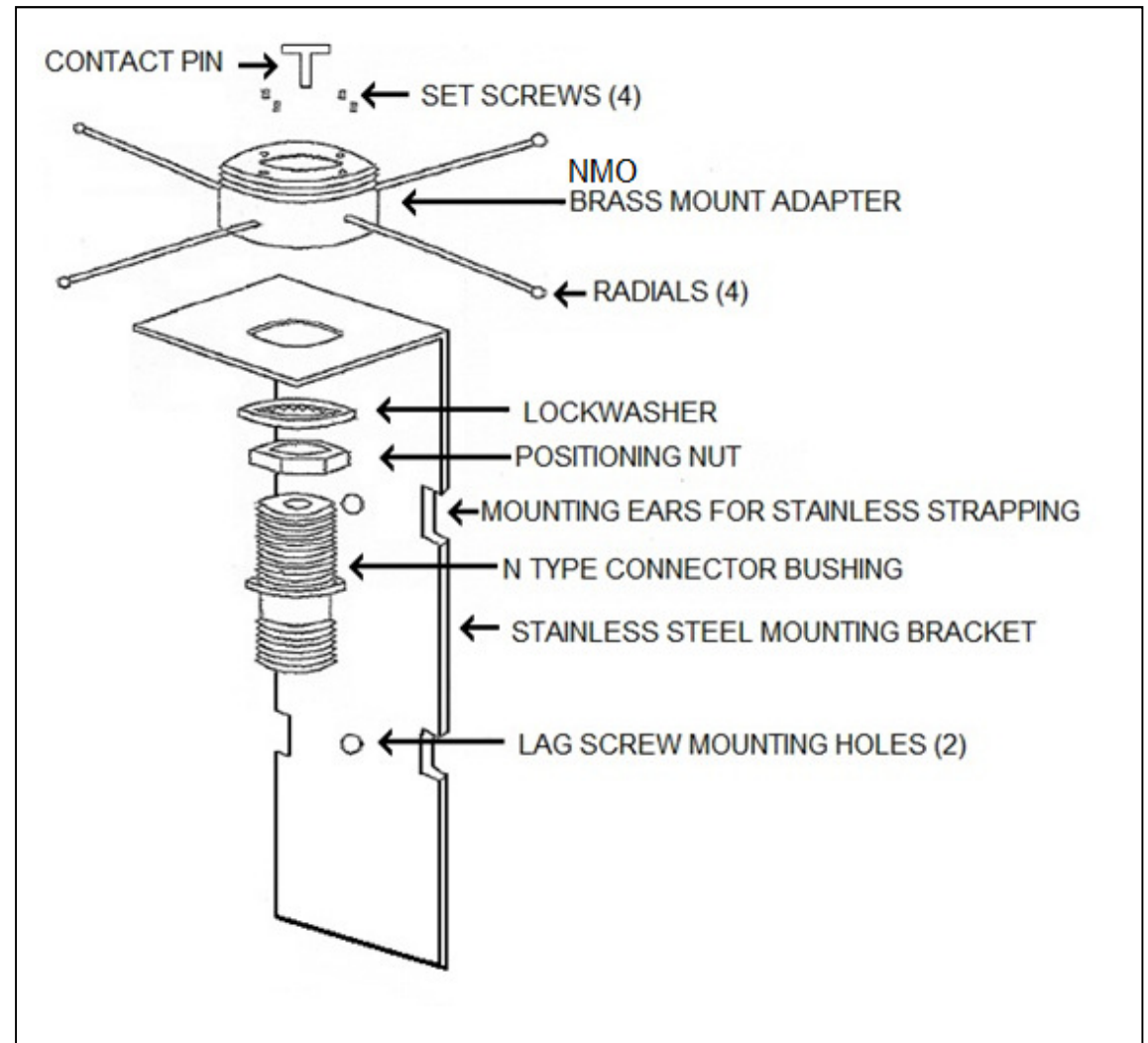

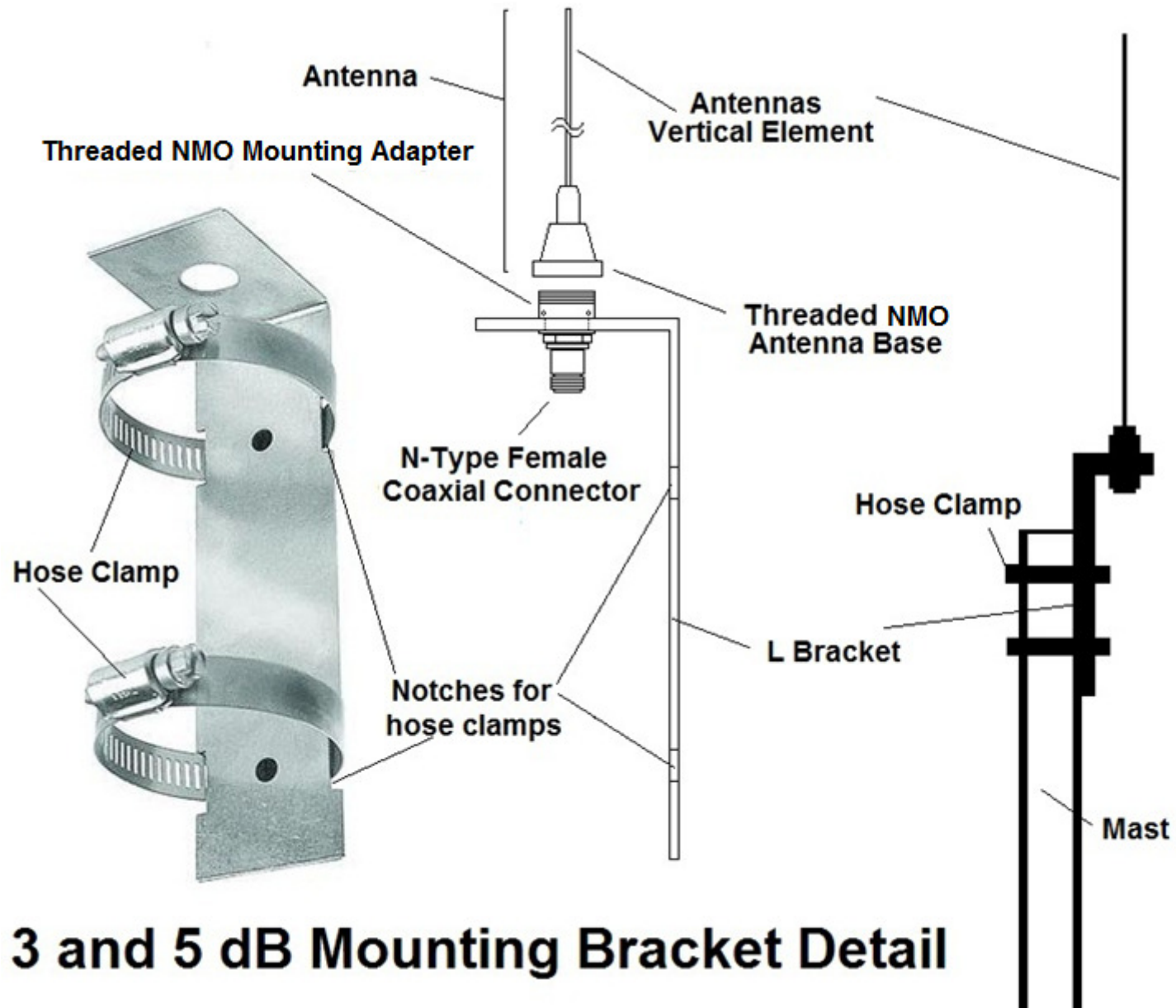

3 and 5 dB Mounting Bracket Detail