AES 940 DCX)R CONTROL MODULE



DESCRIPTION:

Each 940 module controls one (1) door. Each door includes two (2) locks: an emergency lock; and an access lock. Both locks must be released for the door to open. Indicators on the module display the status of the emergency lock, and the door position (open/closed) as sensed by a magnetic contact at the door.

RACK LOCATION: Any Location EXCEPT the first (far left) position

GUARDED TOGGLE SWITCH OPERATION:

Down Position - Releases emergency lock

Middle Position - Locks emergency lock

Up Position - Overrides Emergency Lock Up (see 910 module); releases door during an emergency lock up period

PUSH BUTTON (LIGHTED) SWITCH OPERATION:

Push - Releases access strike lock

STATUS INDICATORS:

Red Lamp - Indicates emergency lock is retracted, confirming that door can be opened

Yellow Lamp - Indicates that door is open

TO OPEN DOORS DURING EMERGENCY LOCK UP:

Lift switch guard and push toggle switch into UP position

INSTALLATION:

In general, wiring should be made in accordance with the wiring diagram(s) provided.

PEABODY ELECTRIC CORPORATION
 255 WASHINGTON STREET
 PEABODY, MASSACHUSETTS 01960

DIFFERENTIAL

It

726 (926) POWER SUPPLY
 Sec Note 1

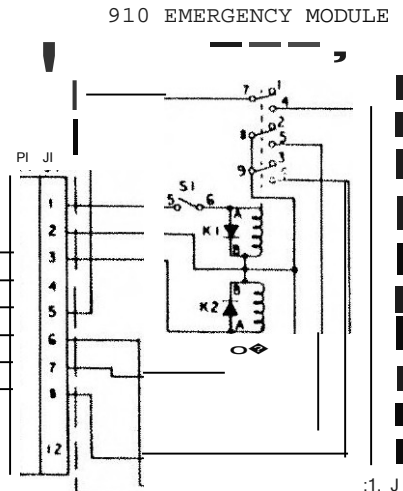
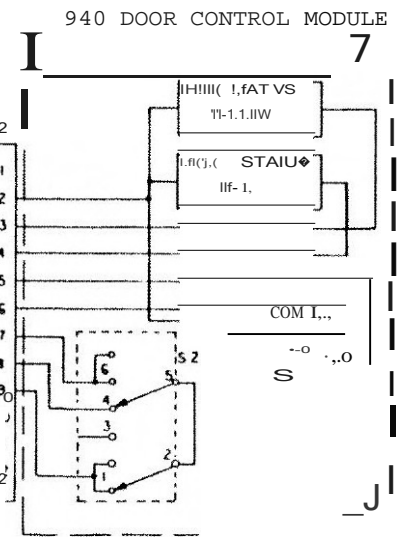
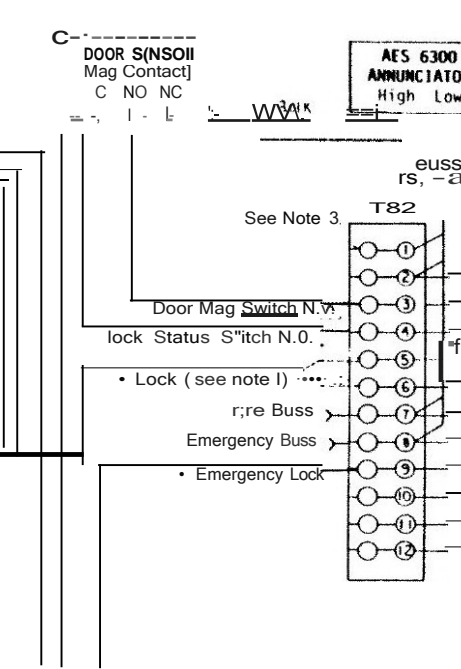
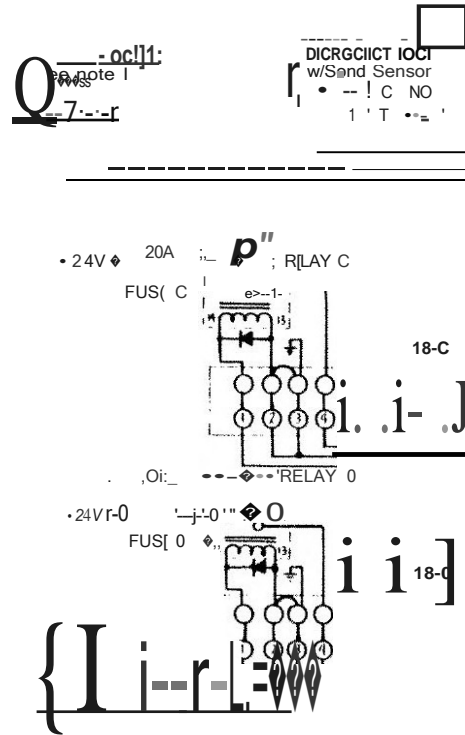

NOTE 1: Either a fail Safe or a Fail Secure lock may be used for an access lock. Note typical wiring shown at terminals Sand 6 on TB-2.

NOTE 2: Power Supply diagram shows only wiring for 1 locks. There are sufficient in/outputs for 4 locks. Other locks are wired to 18-A and TB-8, not shown.

NOTE 3: 187 is corresponds to the 2nd position on the 900 rack. Wiring for T83 to T89 (positions 3 to 9) are wired in the same manner shown here.

TYPICAL WIRING - 900 SERIES
 910 Emergency Module; 940 Door Control Module;
 716 (926) Power Supply; electric locks; 6300 Annunciator

Input	APPLICABLE 91	Output	91/5/11V
Input	HI/5/11V	Output	91/5/11V

PO Box 709.1
 Peabody, Mass. 01960 USA

COORDINATION