

IntelliNet 2.0

AES Solar Subscriber

Installation, Operation and Programming Manual



AES Corporation

285 Newbury Street

Peabody, MA 01960 USA

Tel (978) 535-7310 • Fax (978) 535-7313

www.aes-corp.com

Copyright © 2022 AES Corp. All Rights Reserved

This page deliberately left blank

Table of Contents

| | | |
|-----------|--------------------------------------------------------|-----------|
| 1. | Safety Considerations | 6 |
| 2. | Technical Specifications | 6 |
| 3. | Pre-Installation | 8 |
| 3.1 | Equipment List | 8 |
| 3.2 | Requirements | 8 |
| | Environmental Requirements | 8 |
| 4. | Installation..... | 8 |
| | Mounting the Enclosure..... | 8 |
| | Weather Proofing Steps | 8 |
| 5. | Wiring..... | 9 |
| | Earth Ground Connection | 9 |
| | Battery Connection | 10 |
| | Battery Replacement | 10 |
| | Battery Supervision | 10 |
| | Low Battery Voltage Cutoff | 10 |
| | Discharge/Recharge | 10 |
| 6. | Programming | 12 |
| 6.1 | Programming Interface..... | 12 |
| 6.2 | Logging In..... | 12 |
| | Change Login Password | 12 |
| 6.3 | Solar Subscriber Interface..... | 13 |
| | Page Navigation | 13 |
| | Making Configuration Changes..... | 13 |
| | Saving Configuration Changes..... | 14 |
| 6.4 | View SOLAR Subscriber Software Version | 14 |
| 6.5 | Subscriber Configuration | 14 |
| | Subscriber ID | 14 |
| | Event Reporting Route | 15 |
| 6.6 | Radio Configuration | 16 |
| 6.7 | Central Receiver Configuration..... | 16 |
| 6.8 | Advanced Configuration | 17 |
| 6.9 | Zone Input Configuration..... | 18 |
| | Zone Input Options for Zones 1 though 4 | 18 |
| | Alarm Panel Siren Input Options for Zones 5 and 6..... | 19 |
| 6.10 | Consecutive AT Events..... | 19 |
| 6.11 | Inverted Fire | 19 |
| 6.12 | Restoral..... | 19 |
| 6.13 | Status LED Indicators | 20 |

- ALM LED Blink Pattern Chart.....20
- 6.14 Subscriber Status Check.....21
 - General.....21
 - Routing Table21
 - Hardware21
- 6.15 Tools.....22
 - Text Message22
 - Alarm History22
 - RF Traffic22
 - IP Traffic22
 - RF Antenna Test22
 - Ping23
 - System Activity Log23
- 6.16 IP Configuration23
 - IP Address – Static.....23
- 7. System Settings 23**
 - 7.1 Change Password.....23
 - 7.2 Add User23
 - 7.3 Buzzer – Onboard Subscriber24
 - 7.4 Uploading/Downloading Settings24
 - Download Current Settings24
 - Upload Preconfigured Settings24
 - Reset to Default Configuration24
 - 7.5 System Firmware Update24
 - Updating.....24
 - Download Support Files (from subscriber to PC)24
 - Restart System24
- 8. Flexible Power Option 24**
- 9. Reporting..... 28**
 - 9.1 Compatible Receiver.....28
- 10. Testing..... 28**
- 11. Maintenance..... 28**
- 12. Troubleshooting 28**
- 13. Repair Information 29**
- 14. Contact Information 29**
- 15. Battery Replacement Instructions..... 29**
- 16. Warranty 30**

List of Tables

Table 1. System Status LED Indicators20
Table 2. Blink Patterns20

List of Figures

Figure 1. 7007S Solar Enclosure7
Figure 2. Earth Ground Connection Point9
Figure 3. Connecting the Battery Backup10
Figure 4. Antenna and Surge Suppressor Grounding11
Figure 5. Earth Grounding11

1. Safety Considerations

WARNING! Subscriber antenna or other cables that come in contact with electrical power lines may result in **DEATH** or **SERIOUS INJURY**.

WARNING! Do **NOT** install the subscriber unit during a lightning storm.

- Equipment must be installed in accordance with National Electric Code, NFPA 70, local building codes, and any specific requirements of the Authority Having Jurisdiction (AHJ).
- Ground the antenna, the SOLAR subscriber enclosure, and any surge protector devices to help dissipate surges away from equipment and personnel. Antenna grounding and surge protectors are for your safety and the safety of your equipment.
- **Periodically test the system for proper operation.** AES assumes no responsibility for the equipment’s failure to operate. AES's sole responsibility is to repair or replace any AES device found to be defective during the warranty period.
- Avoid dropping or exposing the unit to physical impact that could damage the enclosure or internal components.

2. Technical Specifications

Power Supply

| | Requirements |
|-------------------------------------------------------|------------------------------------------------------------------------------------------------------------------------------------------------------------------------|
| Solar panel (supplied with unit) | <ul style="list-style-type: none"> • Min. 50W capacity 18V output • Must select “SOLAR” power option in GUI setup |
| 12 V DC from Rechargeable Backup Battery in Enclosure | <ul style="list-style-type: none"> • Minimum 18 Ah size • Must be SLA (gel cell) battery – due to temperature and charge controller limitation |

Environmental Specifications

Operating Temperature: –13F to 185°F (–20°C to 70°C)

Relative Humidity: Non-condensing

Mechanical Specifications

Dimensions: 13.78 in. H × 13.78 W × 5.97 D (Inches)

Weight: 20 pounds with battery

Enclosure Material: Molded fiberglass reinforced polycarbonate, NEMA 4x style

Finish Color: Gray

Inputs

- Alarm Signal Inputs:
4 Zone Input – four each EOL resistor type – All inputs supervised with trouble and restore

Outputs

- Relay Outputs, 4 ea.
- 15 A @ 120 VAC
- 10 A @ 250 VAC

Reporting

- Low Battery (low battery voltage limit: 11.6 V DC)
- Charger Failure

Transceiver

- Output Power: 2 Watts
- Frequency Range: 450–470 MHz standard (Contact AES for other UHF and VHF frequencies.)

Access

- Four each – field wiring, antenna, solar panel power, and vent. See drawing for locations.

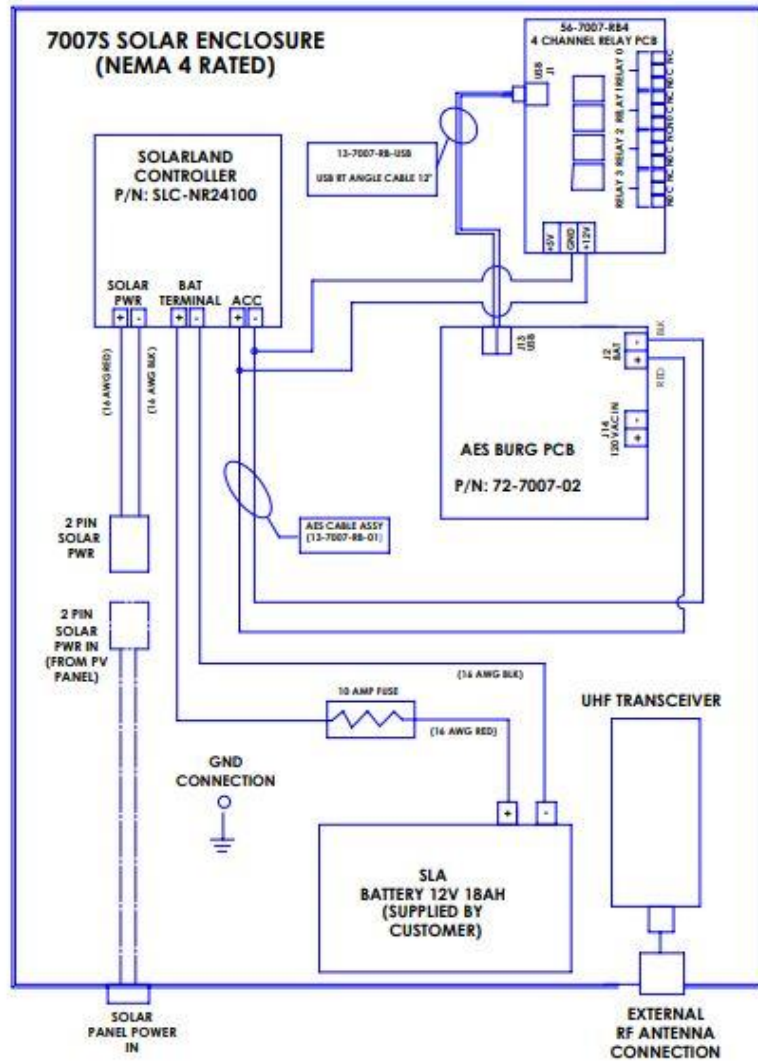

Figure 1. Model 3100S Solar Enclosure

3. Pre-Installation

3.1 EQUIPMENT LIST

The following materials are available out of the box:

- | | | |
|-------------------------------|-------|---------------------|
| • AES Solar Subscriber | 1 ea. | AES P/N 3100S |
| • 18 Ah Gel Cell Battery | 1 ea. | AES P/N 81810 |
| • Subscriber Mounting Bracket | 1 ea. | AES P/N 30-3100-MB |
| • Water proofing tape | 1 ea. | AES P/N 56-7701 |
| • Coax, 10 ft. | 1 ea. | AES P/N 13-0345-10 |
| • Antenna | 1 ea. | AES P/N 7264-PA |
| • Antenna mount bracket | 1 ea. | AES P/N 52-0057 |
| • Quick Start Guide | 1 ea. | AES P/N 40-3100-QSG |
| • Solar Panel | 1 ea. | AES P/N 65-3100-SP |

3.2 REQUIREMENTS

Environmental Requirements

Select an installation location that meets the Environmental Specifications described in the [Technical Specifications](#) section.

Exposing the subscriber to temperatures below -13°F (-20°C) or above 158°F (70°C) can cause unexpected operation of the subscriber electronics.

All the enclosure access points into the enclosure must be adequately sealed against water infiltration.

4. Installation

WARNING! Do NOT install the subscriber unit during a lightning storm or excessive wind conditions.

Mounting the Enclosure

Important! Solar exposure is critical to operation and sun tilt and location during solar exposure must be considered.

Mounting location depends on customer application. Customer must consider the suitability for the application the subscriber will be used for.

Weather Proofing Steps

Important! Use AES supplied water resistant tape and grease to prevent water entering the enclosure. Apply this at each of the cable entries into the enclosure.

5. Wiring

Earth Ground Connection

Earth ground is provided with a terminal. See the lower left corner in Figure 2 below.

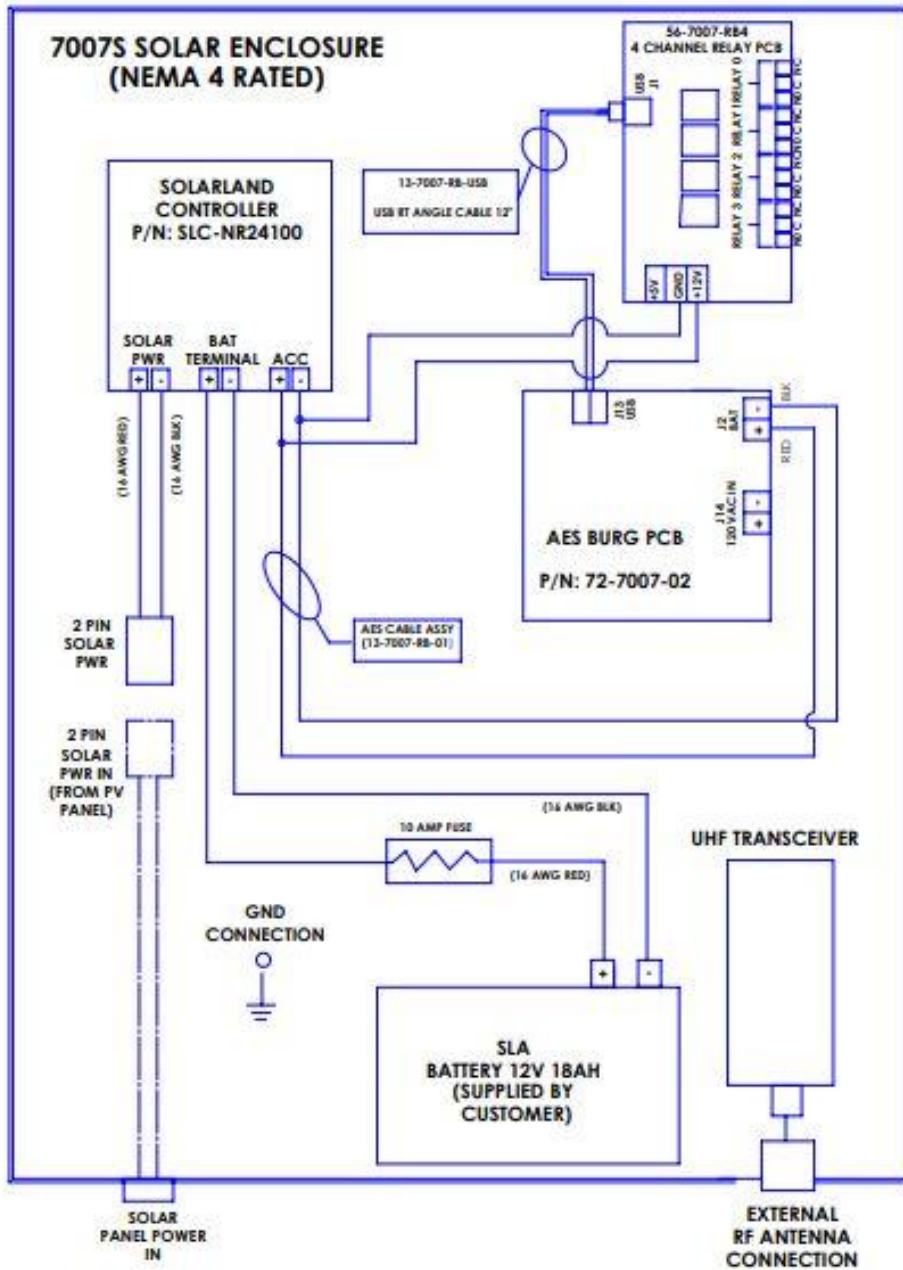

Figure 2. Earth Ground Connection Point

Battery Connection

The charge capacity of the subscriber battery is 18 Ah based on enclosure capability.

To connect the backup battery, refer to the following steps:

1. Connect the **BLACK** wire from (place to the charger terminal) to the negative (-) side of the battery.
2. Connect the **RED** wire from (place to the charger terminal) to the positive (+) side of the battery.

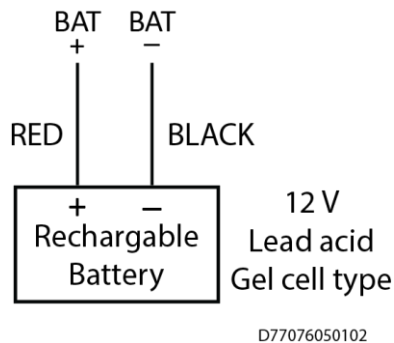

Figure 3. Connecting the Battery Backup

Battery Replacement

The type of battery used should be replaced every 3 years or when your application indicates replacement is required. Replace with the same size and type installed.

Battery Supervision

When solar panel power is present, the battery is tested at approximately 30-second intervals.

When the battery voltage is 11.2 V DC or less for two consecutive test intervals (approximately 60 seconds total), a low-battery trouble message is transmitted.

When solar panel power is present and a low battery reaches a charge voltage above 12 V DC, a restoral message is transmitted.

Low Battery Voltage Cutoff

To prevent damage from deep discharge, the SOLAR subscriber disconnects the battery when voltage is less than 10 V DC.

Discharge/Recharge

The SOLAR panel charges the battery using a charger controller. The battery voltage level conditions are:

- Low Battery (Trouble message): 11.2 V DC or below
- Subscriber Battery Disconnect: Below 10 V DC
- Battery Reconnect (Restoral message): Above 12 V DC

A protective surge suppressor (AES Model 7230) option (separately purchased) may be installed in line with any type of remotely installed antenna, as shown in the diagram below. The surge suppressor and outdoor antenna must be earth grounded.

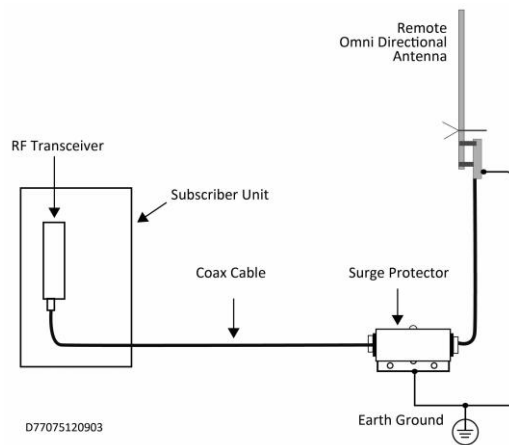

Figure 4. Antenna and Surge Suppressor Grounding

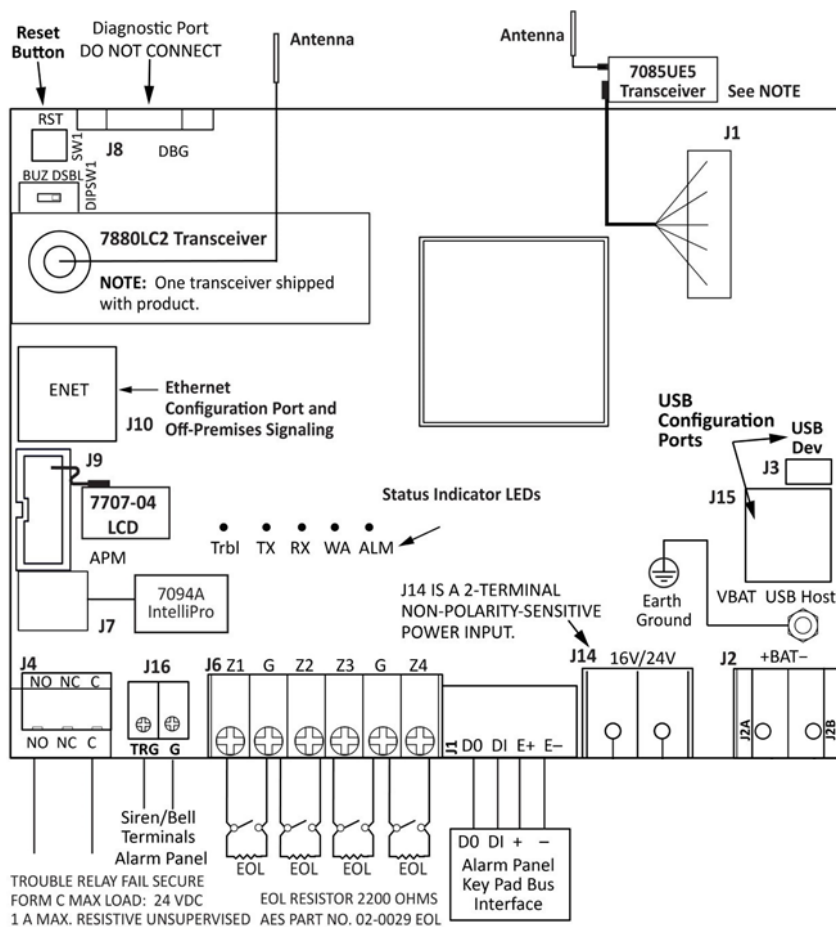

Figure 5. Earth Grounding

6. Programming

6.1 PROGRAMMING INTERFACE

The Model 3100S is programmed using a graphical interface through a smartphone, a laptop/tablet, or other browser-capable device through a Wi-Fi dongle.

The subscriber is connected to a LAN through the J10 Ethernet connector. The default network protocol is DHCP. The IP address obtained is shown in the app only during subscriber power-up. An example display is shown below. The actual IP address will depend on the network the subscriber connects to.

Note: If DHCP is not available, the IP address is set to 169.254.100.1.

6.2 LOGGING IN

Connecting to the SOLAR configuration page requires a login. Enter the IP address of the subscriber into a web browser, then enter your username and password at the login screen. Both the default username and password are admin (lowercase):



The login screen features the AES Corporation logo and IntelliNet 2.0 branding. It contains two input fields: 'User Name' and 'Password', followed by a blue 'Login' button.

The following screen appears after a successful login:

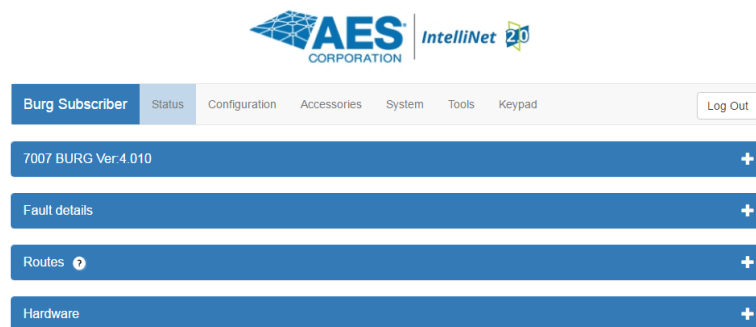

The dashboard displays the AES Corporation logo and IntelliNet 2.0 branding. It features a navigation menu with tabs: 'Burg Subscriber', 'Status', 'Configuration', 'Accessories', 'System', 'Tools', and 'Keypad'. A 'Log Out' button is located in the top right corner. Below the navigation menu, there are four expandable sections: '7007 BURG Ver.4.010', 'Fault details', 'Routes', and 'Hardware', each with a plus sign on the right.

Change Login Password

1. Click the **System** tab as shown below:

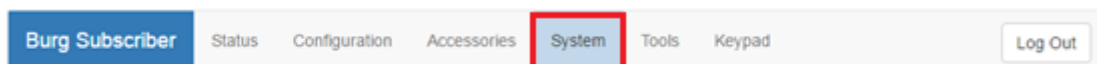

The navigation menu is shown with the 'System' tab highlighted by a red box. The other tabs are 'Burg Subscriber', 'Status', 'Configuration', 'Accessories', 'Tools', and 'Keypad'. A 'Log Out' button is visible on the right.

2. Place the cursor in the Current Password text box. Enter the current password.
3. In the **New Password** text box, type the new password. Type the new password again in the **Confirm** box and click **Change Password**.

6.3 SOLAR SUBSCRIBER INTERFACE

Page Navigation

Individual pages are listed in a tab bar. To go to a page, click the associated tab.

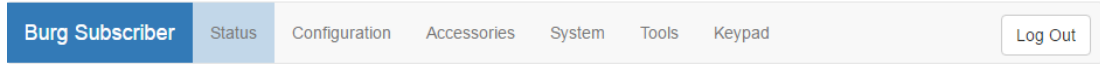

For example, the **Tools** page is accessed by clicking **Tools**:

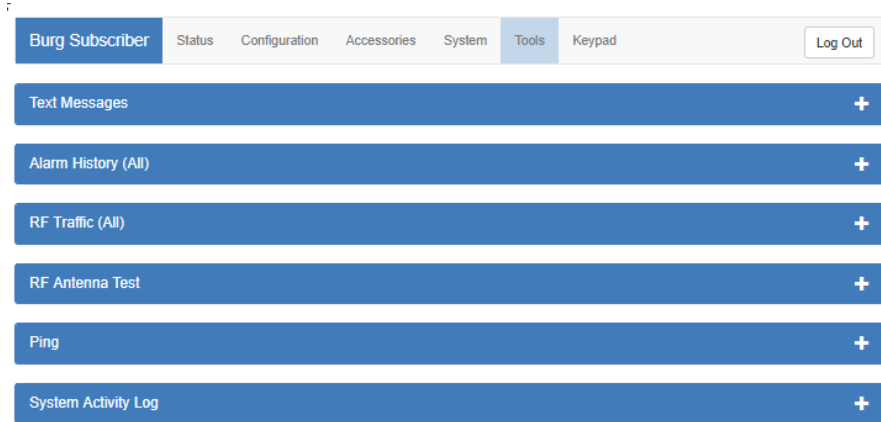

Each page displays a set of controls. Use the **+** control to expand the control window. In this example, expanding **Alarm History** allows you to view messages similar to the example below:

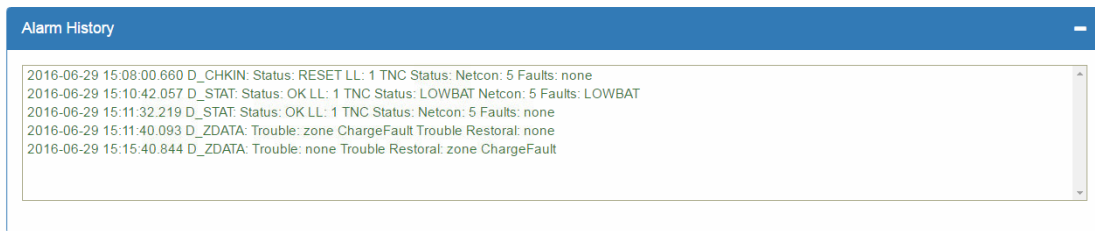

Use the **-** control to collapse the window.

The **Log Out** control ends the configuration session and returns to the **Login** screen.

Making Configuration Changes

Configuration settings are made and changed using either the dropdown or slider switch controls in the window.

The dropdown provides a list to select from:

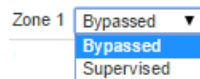

The slider switch provides one of two values to select:



Saving Configuration Changes

Saving configuration changes requires the following steps:

1. When you are finished making changes, select and click **Save Changes**. The **Saved new settings!** acknowledgement appears:

Saved new settings! Click "Update" from menu bar to confirm changes.

2. You may finish and save your changes immediately, or you can make additional changes and then save all changes at once afterward.
3. If done making changes, click the **Update** tab shown in the browser (highlighted in red in the figure below):

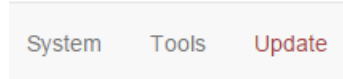

The **Status** window displays changes:

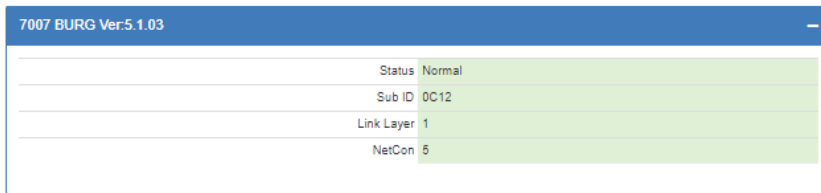

6.4 VIEW SOLAR SUBSCRIBER SOFTWARE VERSION

The SOLAR software version is visible in the **System** tab under the **System Firmware Upgrade** panel.

Select the **System** tab, as shown in the following figure:

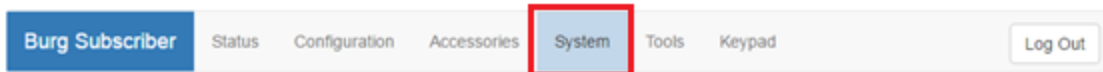

The version number is displayed in the **System Firmware Upgrade** section:

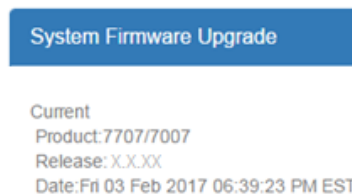

6.5 SUBSCRIBER CONFIGURATION

Subscriber ID

Subscriber ID is set in the **Configuration** tab.

1. From the main menu, select the **Configuration** tab.

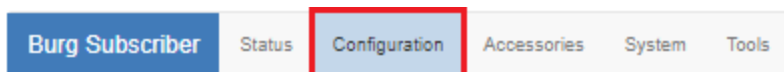

Note: Remote programming of Sub ID and Cipher Code is not possible. Also, the Subscriber ID number must be unique from all other Sub ID numbers in the system.

2. Change the **Sub ID** by entering a four-character hex (0–9 and A–F) identification number. Valid values are **0001** to **FFFF**.

Event Reporting Route

1. From the main menu, click the **Configuration** tab.
2. In the **Event Reporting** panel, click the **Reporting Route** dropdown and select the path for the subscriber to communicate.

Complete the configuration using the links shown below for the Event Reporting path selected for the subscriber:

- **Radio Only:**
- NOTE: Applicable to solar only.
- **Radio and Internet:**
- , [Central Receiver Configuration](#) and Subscriber IP Address under [Advanced Configuration](#).
- **Radio and Internet Backup:**
- , [Central Receiver Configuration](#) and Subscriber IP Address under [Advanced Configuration](#).
- **Internet and Radio Backup:**
- , [Central Receiver Configuration](#) and Subscriber IP Address under [Advanced Configuration](#).
- **Internet Only:** [Central Receiver Configuration](#) and Subscriber IP Address under [Advanced Configuration](#).

6.6 RADIO CONFIGURATION

The **Radio Configuration** panel contains subscriber settings.

To set Radio Configuration:

1. Click the **Configuration** tab.
2. Scroll to the **Radio Configuration** panel.
 - **Cipher:** Enter the four-character hex (0-9 and A-F) cipher code (dealer code) assigned by the system administrator. Valid values are **0000** to **FFFF**.

Note: The code must match the AES 7170 IP-Link cipher code for the network that the subscriber is to join. The subscriber will not join the mesh network if the cipher code is incorrect.

- **Check-In Time:** Enter **Check-In interval time in hours and minutes. The default is 23:45 (23 Hr. 45 Min).**

Note: Using short Check-In times generates more traffic on the network.

- **Communication Timeout:** Communication Timeout is the time the subscriber waits for an ACK as a reply to a transmitted packet before going into RF Trouble mode. The range is 1–300 seconds. The default (recommended) time is 120 seconds.
- **Repeating:** Set **Repeating** to **Enabled/Disabled** by clicking the **Repeating** switch.

6.7 CENTRAL RECEIVER CONFIGURATION

The **Central Receiver** panel contains Internet connection settings to the MultiNet/INCC receiver.

To set Central Receiver Configuration:

1. Click the **Configuration** tab.
2. Scroll to the **Central Receiver** panel.
 - **IP Group ID:** Enter the assigned IP Group ID found in Business Unit Settings.
 - **Primary Receiver IP:** Enter the Primary receiver IP address.
 - **Primary Receiver Port:** Enter the Primary receiver port number.

NOTE – The following is applicable to dual receiver setups only.

- **Secondary Receiver IP:** Enter the Secondary receiver IP address.
- **Secondary Receiver Port:** Enter the Secondary receiver port number.
- **Internet Check-In:** Enter the check-in time interval for the subscriber.
- **MCT Delay:** Enter the MCT (Multiple Communications Technology) Timeout. The MCT Timeout sets the amount of time the subscriber tries to send messages though one communication technology before giving up and switching to the other technology.

6.8 ADVANCED CONFIGURATION

From the **Advanced Configurations** menu, you can configure Secondary Alarm Delay, TTL (Time to Live) and subscriber IP address settings. To configure these settings:

1. Select the **Configuration** tab.
2. Scroll to the **Advanced Configuration** panel.
 - **Secondary Alarm Delay**
Enter the number of seconds to allow between data transmissions from the subscriber. The range is 1–330 seconds. The default (recommended) time is 10 seconds.

Note: The first message is sent immediately without delay. Messages that follow are delayed.

- **TTL (Time-To-Live) Configuration**
Time-to-Live settings are for managing the performance of the AES mesh network. TTL is the length of time a packet message transmission for a specific setting is retried by a subscriber in the AES mesh network. The subscriber will stop attempting to transmit the packet when the TTL limit has expired.

To set Time-to-Live:

1. Scroll to the **Configuration** tab.
2. Select the **Advanced Configuration** panel and configure the setting:

| Message Type | TTL |
|--------------|------------|
| CHECK-IN | 10 minutes |
| STATUS | 10 minutes |
| ALARM | 3:00 hours |
| TROUBLE | 3:00 hours |
| RESTORAL | 3:00 hours |
| INTELLIPRO | 3:00 hours |
| SPECIAL | 10 minutes |

- **Subscriber IP Address Information**

To set the subscriber IP address (applicable only if IP access is available and used):

1. Scroll to the **Configuration** tab.
2. Select the **Advanced Configuration** panel and configure the setting:
Subscriber IP Address type: Select **STATIC** or **DHCP**

If **STATIC** address is selected, enter the following information:

- IP Address – The IP address of the subscriber
- Subnet Mask
- Gateway
- DNS Server 1 (Optional)
- DNS Server 2 (Optional)

6.9 ZONE INPUT CONFIGURATION

Zone input for the Model 3100S. The 7094A IntelliPro configuration note applicable. See **Accessories** tab.

You can verify that a 7094A IntelliPro is installed by selecting the **Status** tab and checking the **Hardware** panel.

To configure zone inputs on the SOLAR click the **Accessories** tab shown below:

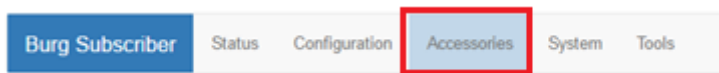

The SOLAR subscriber has six zone inputs, zones 1 through 6, as shown below:

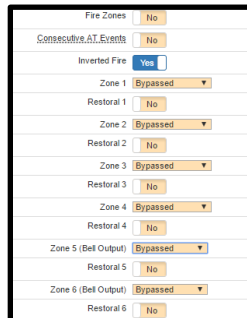

Zone Input Options for Zones 1 though 4

The following options are the default choices on the dropdown menu of Zones 1 through 4:

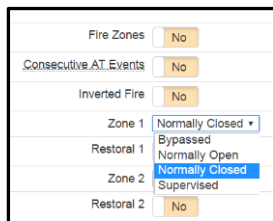

- Bypassed** – zone input is ignored
- Normally Open**
- Normally Closed**
- Supervised**

When the **Fire Zones** switch is set to **Yes** and **Inverted Fire** is set to **Yes**, then the **Fire** and **Inverted Fire** options will be listed in the dropdown options as shown below:



| Zone Input Condition | Zone Programming | | | |
|-------------------------------|------------------|---------------|---------|---------------|
| | Supervised | Bypass | Fire | Inverted Fire |
| 2.2k ohm EOL resistor circuit | Normal | Input Ignored | Normal | Normal |
| Open circuit | Alarm | Input Ignored | Trouble | Alarm |
| Short/closed circuit | Alarm | Input Ignored | Alarm | Trouble |

Alarm Panel Siren Input Options for Zones 5 and 6

Inputs for zones 5 and 6 pertain to security alarm panel siren output. The alarm panel condition is detected by the subscriber through the zone input and a message sent to the central monitoring station. The following types of **Siren Alarm** input types can be programmed for zones 5 and 6:

- Bypassed – zone input is ignored
- Temporal/Pulse alarm pattern
- Steady/Even alarm pattern

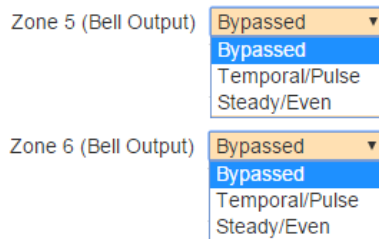

Connect the Alarm Panel Siren terminals to the SOLAR subscriber siren input terminals.

6.10 CONSECUTIVE AT EVENTS

Set **Consecutive AT Events** to **Yes** for verbose reporting of alarm and trouble messages. This means that alarms and trouble will be sent continuously alarm-trouble-alarm-trouble. Set to **No** for non-verbose reporting, which means that an alarm can be sent, then a trouble, but if an alarm happens again without a restoral, the alarm will not be sent.

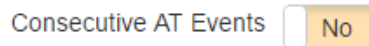

6.11 INVERTED FIRE

Set **Inverted Fire** to **Yes** for an *open* zone input to report as an *alarm* and a *short* on a zone input report as *trouble*. Otherwise, the default setting of **No** which reports open on a zone input as trouble and a short on a zone input as an alarm (if Fire Zones = Yes).



Note: Set all *unused* zones to **Bypassed**. Do *not* install EOL resistors on **Bypassed** zones.

6.12 RESTORAL

Restoral messages are sent for the zone when the **Restoral** switch is set to **Yes**.

6.13 STATUS LED INDICATORS

The four LED indicators on the Model 3100S main circuit board show the system status. The LEDs are located in the lower left corner of the circuit board above the **J6** connector:

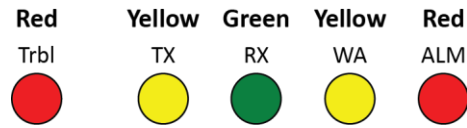

| Table 1. System Status LED Indicators | | |
|---------------------------------------|--------|-----------------------------------------------------------------------------------------------------------------------------------------------------------------------------------------------------------------------------------------------------------------------------------------|
| LED | Color | Function |
| ALM | Red | Status / troubleshooting indicator, "blink" |
| WA | Yellow | Steady On = Waiting for acknowledgment of last transmission Steady Blinking = Not on Network; Off = Normal |
| TX | Yellow | On = radio transmit |
| RX | Green | On = Radio transceiver receiving RF signal. NOTE: If RX is on steady longer than 20 seconds, then there is an interfering RF signal. Any RF signals on the same frequency as the subscriber and strong enough to break the squelch will also cause the RX light to remain on. |
| Trbl | Red | Blinking Continuously = Trouble Output Condition |

ALM LED Blink Pattern Chart

The chart below shows blink patterns displayed by the **ALM LED** and what each blink pattern means.

| Table 2. Blink Patterns | | |
|-------------------------------|----------------------|--------------------------------------------------|
| Blink Type | Pattern | Possible Meaning(s) |
| Steady blink | ■ ■ ■ ... | Normal operation |
| Short-short blink | ■■ ■■ ■■ ... | Low battery |
| Short-long | ■ ■■■ ■■■ ■■■ ... | Zone input in alarm or trouble/off normal |
| Short-short-long | ■■■■ ■■■■ ■■■■ ... | Low battery and zone in alarm/trouble |
| Short-short-pause-short | ■■ ■ ■■ ■ ■■ ■ ... | AC Fault |
| Short-short-pause-short-short | ■■■■ ■■ ■■ ■■ ■■ ... | AC Fault and low battery |
| Steady/no blink | ————— | Self-test failure (excluding low battery and AC) |

Symbols as follows: "■" = short blink, "■■■■" = long blink

Period between patterns is about 1 second. The chart shows the pattern repeated 3 times.

6.14 SUBSCRIBER STATUS CHECK

General

Information about the Model 3100S subscriber is shown from the **Status** tab.

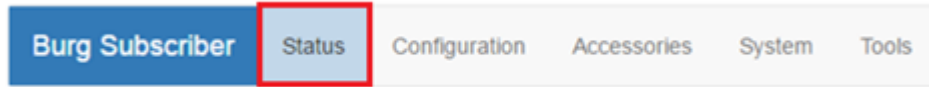

The **Status** page shows any faults, as well as the unit (subscriber) RF ID, Link Layer, and NetCon values:

| | |
|------------|--------|
| Status | Normal |
| Sub ID | CC16 |
| Link Layer | 1 |
| NetCon | 5 |

If faults are present, they are displayed.

Routing Table

The subscriber routing table is shown in the **Routes** panel, as shown in the example below. Up to eight routes may be shown:

| Routes | |
|--------|--------------------|
| 1 | 3333 L:00 N:0 Q:03 |
| 2 | 1007 L:01 N:5 Q:03 |
| 3 | 1008 L:01 N:5 Q:03 |

Hardware

Information about the subscriber type, serial number, alarm panel type, and IP addresses are shown in the **Hardware** panel.



- **Model Type** – The Model 3100S, a Security subscriber, displays as type Burg.
- **Serial Number** – A unique serial number is assigned to each Model 3100S subscriber at the factory.
- **Zone Bank**
- **Panel Interface** – The panel interface type detected during configuration is shown.
- **WiFi IPv4** – The address to an optional plug-in Wi-Fi adapter for wireless communications with the subscriber during configuration.

The following are applicable only with IP access:

- **Wired MAC** – The Media Access Control (MAC) address (which is the physical address) is a unique network identifier assigned to the Model 3100S subscriber.
- **Wired IPv4** – The IP address of the subscriber.

6.15 TOOLS

The **Tools** tab provides access to the following:

- Text Messages
- Alarm History
- RF Traffic
- IP Traffic
- RF Antenna Test
- Ping
- System Activity Log

To access these features, select the **Tools** tab as shown in red below:

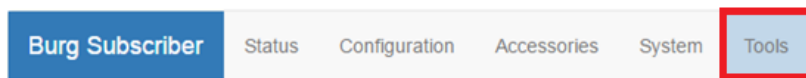

Text Message

A text message can be sent from the SOLAR subscriber to the central monitoring station. Messages from the central station can also be received.

In the **Text Messages over RF** panel, use the message line at the bottom of the panel to enter the message. Messages have a 200-character limit. Click **Send** to transmit the message.

 A screenshot of the 'Text Messages over Air' panel. It features a large text area for messages, a smaller input field at the bottom with the placeholder text 'Type message here (limited 200 characters) ...', and a blue 'Send' button below the input field.

Alarm History

Messages sent from the alarm panel through the Model 3100S subscriber are displayed in the **Alarm History** user interface panel.

RF Traffic

Receive and Transmit traffic to/from the subscriber can be viewed using the **RF Traffic** panel. Traffic from other subscribers can also be viewed.

IP Traffic

Messages that are sent to and from the Subscriber, and which are used for debugging purposes, are displayed in the **IP Traffic** panel.

RF Antenna Test

The RF Antenna Test turns the transceiver transmitter on for approximately 5 seconds and allows use of RF test equipment, such as a SWR meter or power meter. This function allows you to check transceiver RF power output, coaxial cable connections, antenna tuning, and other parameters.

Ping

The ping utility checks the network connectivity of the subscriber. Enter a network address on the address line and click **Submit** to verify the connection.

System Activity Log

The System Activity Log shows SOLAR subscriber information used for diagnostic purposes.

6.16 IP CONFIGURATION

The IP address of the Subscriber is set in the **Configuration** tab under the Advanced Conf. Fixed (static) or automatically assigned (DHCP) addresses may be used. DHCP addressing is the default network address setting.

Select the **IP Configuration** tab.

IP Address – Static

When **Static** is selected, the form expands to show:

- IP Address
- Subnet Mask
- Gateway
- DNS Server 1 (Optional)
- DNS Server 2 (Optional)

Obtain information for these settings from the network administrator or other individual who manages network services.

7. System Settings

The **System** tab provides access to system setting features.

7.1 CHANGE PASSWORD

Change Password allows the logged-in user to set another password for the login account. If the user is logged in with a default account password, a warning about changing the password appears in red letters.

The **Login User** line displays the current user logged into the subscriber.

To change the password:

1. Enter the existing password into the “Current Password” field.
2. Enter a new password into the “New Password” field.
3. Re-enter the new password again into the “Confirm” field.

7.2 ADD USER

Add User allows you to add additional users to the system.

To add a user:

1. Enter the username into the “Username” field.
2. Enter the password into the “Password” field.
3. Re-enter the password again into the “Confirm” field.
4. When through, click the **Add User** button.

7.3 BUZZER – ONBOARD SUBSCRIBER

Not applicable to Solar subscriber. The buzzer control enables or silences the onboard subscriber buzzer. The default setting is **Enabled**.

1. To disable, click the **Enable** control so that it changes to **Disabled**.
2. When through, click the **Save Change** button.

7.4 UPLOADING/DOWNLOADING SETTINGS

Download Current Settings

Setting information can be downloaded from the subscriber. Select the **RF Config** or **IntelliPro Config** button and click the **Download** button.

Upload Preconfigured Settings

To upload subscriber settings to the Model 3100S, click **Choose File**, select the file, and click **Upload**.

Reset to Default Configuration

Subscriber and **IntelliPro** settings can be set to factory defaults.

1. Set the **Subscriber Config** and/or **IntelliPro Config** switch to **Yes**.
2. Click the **Reset Configuration** button.

Note: Reset with **Subscriber Config** *does not change* the existing Subscriber ID and Cipher code programmed in the unit.

7.5 SYSTEM FIRMWARE UPDATE

Updating

To update the subscriber software, click **Choose File**, select the upgrade file, and click **Update**.

Download Support Files (from subscriber to PC)

To download system information files, select the file type from the **Select file type** dropdown box, then click **Download**.

Restart System

Clicking the **Restart** button causes the Subscriber to halt communication and any system software that may be running. The system software restarts and the Subscriber resumes communication.

8. Flexible Power Option

Subscriber power can be provided by several different types of power sources. This control configures the type of power source and the features associated with the power source. From the **Configuration** tab, select the **Flexible Power Option** panel.

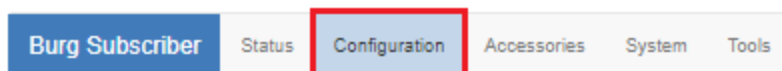

For power source details, see [Figure 4](#).

- Use the Solar Panel selection from the **Power From** dropdown. .

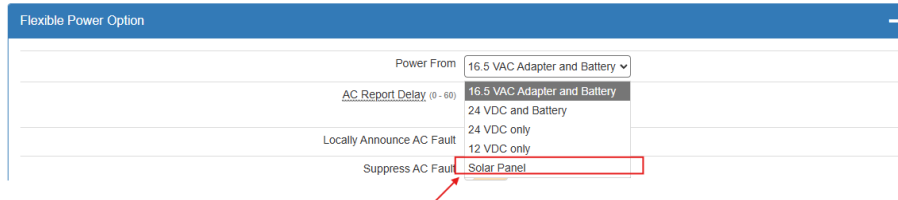

Note: Can only select Solar Option

Important! When using this selection, **16.5 V AC** is the *primary* power source and the **battery** is the *secondary* power source.

- **AC Report Delay:** AC Report Delay is active when **Suppress AC Fault** is set to **NO**. The report delay is the time that must pass before the Model 3100S Subscriber will send an AC failure or AC restoral message. This feature helps prevent mesh network congestion in an area where many Subscribers have an AC power outage at the same time. Messages can be set to transmit in a staggered fashion using the Random time setting.

The combined AC fail detection time delay of 100 minutes plus the random **AC Report Delay** between 0–60 minutes results in time that does not exceed 160 minutes.

AC power must be lost for 100 minutes in order to be detected as a failure. AC power must be restored for at least 100 minutes in order to be detected as a restore. Once either is detected, a message is created by the subscriber and is sent to the central station.

An AC report delay is selected based on both this parameter and the setting of AC fault report suppression in the setting of **Suppress AC Fault Reporting**.

- **AC Report Delay** – Available settings:
 - **Random Delay:** A random time ranging from 0–60 minutes after 100 minutes of AC power loss. Enter R into the box.
 - **Fixed delay:** A specific time ranging from 1–60 minutes after 100 minutes of AC power loss.
 - **No Delay:** Immediate transmission after 100 minutes of AC power loss. This is not recommended.
- **Locally Announce AC Fault:** Set **Locally Announce AC Fault** to **Yes/No** by clicking the **Locally Announce AC Fault** switch.
- **Suppress AC Fault Reporting:** Set **AC Fault Reporting** to **Yes/No** by clicking the **AC Fault Reporting** switch.
- **Suppress Battery Fault Reporting:** Set **Battery Fault Reporting** to **Yes/No** by clicking the **Battery Fault Reporting** switch.
- **Suppress Charger Fault Report:** Set **Suppress Charger Fault Report** to **Yes/No** by clicking the **Suppress Charger Fault Report** switch.

When changes are complete, click **Save Changes**.

- Power from 24 V DC and Battery

Refer to the [Wiring](#) section for supply and connection requirements.

Important! When using this selection, **24 V DC** is the *primary* power source and the **battery** is the *secondary* power source.

- **DC Report Delay:** DC Report Delay is active when **Suppress DC Power Fault** is set to **No**. The report delay is the time that must pass before the Model 3100S subscriber will send a primary power failure or primary restoral message. This feature helps prevent mesh network congestion in an area where many subscribers experience a power outage at the same time. Messages can be set to transmit in a staggered fashion using the **Random** time setting.

The combined DC fail detection time delay of 100 minutes plus the random **DC Report Delay** between 0–60 minutes results in time that does not exceed 160 minutes.

Primary (24 V DC) power must be lost for 100 minutes to be reported as a failure.

Primary (24 V DC) power must be restored for at least 100 minutes to be reported as a restore. Once either is detected, a message is created by the subscriber to send to the central station. A **DC Report Delay** is selected based on this parameter and the setting of **Suppress DC Fault** reporting.

Available settings:

- **Random Delay:** A random time ranging from 0–60 minutes after 100 minutes of primary (24 V DC) power loss. Enter R into the box to select this option.
- **Fixed delay:** A specific time ranging from 1–60 minutes after 100 minutes of primary (24 V DC) power loss.
- **No Delay:** Immediate transmission after 100 minutes of Primary (24 V DC) power loss.
- **Locally Announce DC Fault:** Set **Locally Announce DC Fault** to **Yes/No** by clicking the **Locally Announce DC Fault** switch.
- **Suppress DC Power Fault:** Set **Suppress DC Power Fault** to **Yes/No** by clicking the **Suppress DC Power Fault** switch.
- **Suppress Battery Fault Reporting:** Set **Battery Fault Reporting** to **Yes/No** by clicking the **Battery Fault Reporting** switch.
- **Suppress Charger Fault Reporting:** Set **Suppress DC Charge Fault** to **Yes/No** by clicking the **Suppress Charger Fault Reporting** switch.

When done with changes, click the **Save Changes** button.

- **Power From:** 24 V DC only

Refer to the [Wiring](#) section for supply and connection requirements.

Note: The **Suppress Battery Fault** and **Suppress Charger Fault** are grayed out in the interface and cannot be changed when using this setting.

The screenshot shows a window titled "Flexible Power Option". At the top, there is a blue header bar. Below it, the "Power From" dropdown menu is set to "24 VDC only". There are three toggle switches: "Suppress DC Power Fault" is set to "No", "Suppress Battery Fault" is set to "Yes", and "Suppress Charger Fault" is set to "Yes". A blue "Save Change" button is located at the bottom center.

- **Suppress DC Power Fault:** Set **Suppress DC Power Fault** to **Yes/No** by clicking the **Suppress DC Power Fault** switch.

When done with changes, click **Save Changes**.

- **Power From:** 12 V DC only

Refer to the [Wiring](#) section for supply and connection requirements.

Note: The **Suppress Battery Fault** and **Suppress Charger Fault** are grayed out in the interface and cannot be changed when using this setting.

The screenshot shows the "Flexible Power Option" window with "Power From" set to "12 VDC only". A green informational banner at the top states: "With this selection, the 7085UE5 transceiver will operate at 50 - 60% of full radio power output capacity." The "Suppress DC Power Fault" toggle is set to "No". The "Suppress Battery Fault" and "Suppress Charger Fault" toggles are grayed out and set to "Yes". A blue "Save Changes" button is at the bottom.

- **Suppress DC Power Fault:** Set **Suppress DC Power Fault** to **Yes/No** by clicking the **Suppress DC Power Fault** switch.

When done with changes, click the **Save Changes** button.

The screenshot shows the "Flexible Power Option" window with "Power From" set to "Solar Panel". The "Suppress DC Power Fault" and "Solar Panel Supervision" toggles are set to "No". The "Suppress Battery Fault" and "Suppress Charger Fault" toggles are set to "Yes". Below these are four input fields: "Solar Panel Rating in Watts (35, 50, 100, etc.)", "Battery Capacity in AH (18, 35, 100, etc.)", "GPS Latitude (12.345678, etc.)", and "GPS Longitude (12.345678, etc.)". A blue "Save Changes" button is at the bottom.

- Solar panel power option. User must enter Panel Rating and Battery Capacity

- Suppress DC Power Fault: **Set Suppress DC Power Fault to Yes/No by clicking the Suppress DC Power Fault switch.**

When done with changes, click on the **Save Changes**

9. Reporting

9.1 COMPATIBLE RECEIVER

The SOLAR Subscriber is compatible with the AES Corp. Model 7705i/7705ii MultiNet and INCC Receivers.

10. Testing

Some of the tests to be performed at the installation site require a response from a person at the monitoring station:

- Trigger alarm conditions: Confirm that the proper message is received at the Monitoring Station.
- Cause fault conditions: Confirm that the proper message is received at the Monitoring Station.

11. Maintenance

Important! Test system periodically to ensure proper operation.

Once installed and normal operation is confirmed, minimal maintenance is required. Monitoring the automatic check-in test messages will confirm proper RF operation. Batteries should be periodically tested to be certain they have sufficient capacity to operate the system.

12. Troubleshooting

Observe the RX LED on the main circuit board. If the LED is on steady or is on for most of the time, RF interference may be affecting the transceiver.

The most common causes of an RF failure or trouble are due to:

- Antenna type
- Antenna location
- Coaxial cable
- Coaxial connectors
- Transceiver malfunction

Antennas close to metal or conductive material blocking or reflecting the transmitted signal are the most common problem.

Try different locations for the antenna or use a remotely mounted long-range RF antenna. Try replacing the transmission components, including the coaxial cable, coaxial connectors, and/or antenna.

Note: No user serviceable components are located on the circuit boards. Defective circuit board units must be returned to AES. For information on returning units, see the [Return Material](#) section at the end of the Warranty.

13. Repair Information

The SOLAR Subscriber contains no user serviceable parts.

14. Contact Information

AES Corporation

285 Newbury Street

Peabody, Massachusetts 01960 USA

Website: <http://www.aes-corp.com>

AES corporate Phone: (800) 237-6387 (800) AES-NETS

USA (978) 535-7310

Fax: USA (978) 535-7313

Email: Check Website for latest email addresses

15. Battery Replacement Instructions

1. Remove the positive battery lead (red) from the battery.
2. Remove the negative battery lead (black) from the battery.
3. Verify the POWER LED indicator is **NOT** illuminated.
4. Remove the battery from the enclosure.
5. Discard the battery in accordance with local disposal codes.
6. Install the new battery into the enclosure.
7. Connect the negative battery lead (black) to the battery.
8. Connect the positive battery lead (red) to the battery.
9. Perform subscriber power-up and self-test procedure.

16. Warranty**OWNER WARRANTY - AES CORPORATION****LIMITED PRODUCT WARRANTY AND TECHNOLOGY LICENSE****LIMITED PRODUCT WARRANTY:**

AES warrants to the original purchaser that the AES Subscriber Unit will be free from defects in material and workmanship under normal use and service for three (3) years from the date of original purchaser's purchase. Except as required by law, this Limited Warranty is only made to the original purchaser and may not be transferred to any third party.

AES warrants to the original purchaser that the Solar Panel will be free from defects in material and workmanship under normal use and service for one (1) year from the date of original purchaser's purchase. Except as required by law, this Limited Warranty is only made to the original purchaser and may not be transferred to any third party.

This Limited Product Warranty is made in lieu of any other warranties, expressed or implied, it being understood that all other warranties, expressed or implied, including of merchantability or fitness for a particular purpose, are hereby expressly excluded.

AES assumes no liability for any personal injury, property damage, consequential damages, or any other loss or damage due, among other things, to this product's failure to operate or provide adequate warning. AES's sole responsibility is to repair or replace, at AES's sole option, the AES product that is judged defected by AES during the limited warranty period under the terms of its Limited Warranty.

TECHNOLOGY LICENSE:

Certain AES Products include software, protocols and other proprietary and confidential technology and trade secrets of AES which are incorporated in or provided with AES Products solely for use in conjunction with and in order to operate AES Products ("Licensed Technology"). AES grants the original purchaser a non-exclusive license to use such Licensed Technology solely in connection with the use and operation of AES Products and for no other purpose or use whatsoever. No title or ownership in or to any such Licensed Technology is conveyed by the sale or delivery of any AES Products; all such rights are retained by AES.

AES SERVICE PROCEDURE: Contact AES by Phone (978) 535-7310, Fax (978) 535-7313 or Email service@aes-intellinet.com, to receive a Return Material Authorization Number. Have the AES part number and serial number ready. Repack equipment in original or equivalent packaging. Inside the box, please include a contact name, telephone number, address, and a brief description of the reason for return.

Ship items freight-prepaid to:

Repair Services, RMA# _____
 AES Corporation,
 285 Newbury Street
 Peabody, MA 01960 USA

(Contact AES for Return Material Authorization number)